

# HP287 Shaft Specifications & Capacities

### Shaft Material:

Ø2.875" x 0.203" wall  
 ASTM A500 Grade B or C  
 Yield strength = 60 ksi (min)  
 Tensile strength = 70 ksi (min)

### Helix Plates:

ASTM A572 Grade 50  
 3/8" thick (standard)  
 1/2" thick (available)  
 Helix plate geometry conforming to ICC-ES AC358

### Surface Finish of Shaft Segments:

Available plain or hot-dip galvanized<sup>(2)</sup>

### Shaft Coupler Material:

Ø3.500" x 0.281" wall  
 ASTM A513 Type 5 Grade 1026  
 Yield strength = 70 ksi (min)  
 Tensile strength = 80 ksi (min)

### Shaft Coupling Hardware:

(2) - Ø3/4" Grade 5 bolts with nuts  
 Electrocoat plated per ASTM B633

Nominal Thickness	0.203 (in)
Design Thickness <sup>(3)</sup>	0.189 (in)

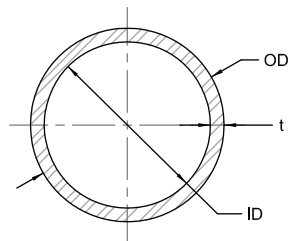

	Plain	Plain Corroded <sup>(1)</sup>	Galvanized Corroded <sup>(1,2)</sup>
OD (in)	2.875	2.839	2.865
t (in)	0.189	0.153	0.179
ID (in)	2.497	2.533	2.507
A (in <sup>2</sup> )	1.59	1.29	1.51
I (in <sup>4</sup> )	1.45	1.17	1.37
S (in <sup>3</sup> )	1.01	0.82	0.96
Z (in <sup>3</sup> )	1.37	1.11	1.29
r (in)	0.95	0.95	0.95
Shaft Max Allowable Compression Capacity <sup>(4,5)</sup> P <sub>n</sub> /Ω (kips)	55.8	45.2	52.9
Shaft Max Allowable Tension Capacity <sup>(5)</sup> P <sub>n</sub> /Ω (kips)	30.6	23.6	27.6

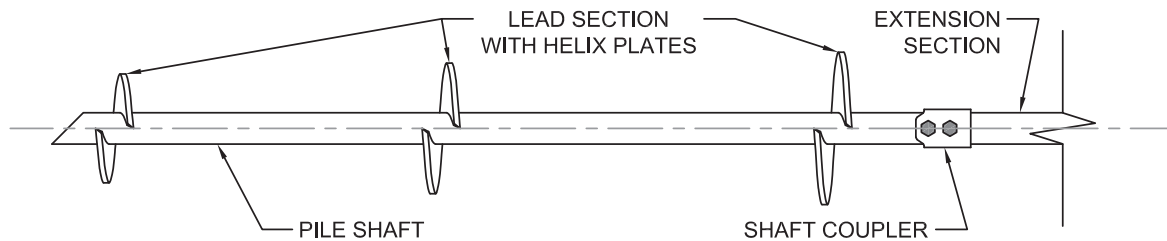

Default Torque Correlation Factor <sup>(6)</sup> K <sub>t</sub> = 9 (ft <sup>-1</sup> )	Maximum Ultimate Soil Capacity <sup>(7)</sup> Q <sub>u</sub> = 50.4 (kips)
Maximum Installation Torque T = 5,600 (ft-lb)	Maximum Allowable Soil Capacity <sup>(7)</sup> Q <sub>a</sub> = 25.2 (kips) FOS = 2.0

- (1) Corroded properties and capacities include a 50-year scheduled sacrificial loss in thickness per ICC-ES AC358.
- (2) Hot-dip galvanized coating in accordance with ASTM A123.
- (3) Design thickness for HSS and Pipe based on 93% of nominal thickness per AISC.
- (4) Allowable capacities consider continuous lateral soil confinement of fully embedded piles. Piles with exposed unbraced lengths or piles placed in fluid soils should be evaluated on a case-by-case basis by the project engineer.
- (5) Listed mechanical capacities are for the shaft and coupled connections only. System capacity should also not exceed the installed allowable torque-correlated soil capacity or the allowable capacity of the respective bracket (see additional bracket tables).
- (6) Default K<sub>t</sub> factor is consistent with that listed in ICC-ES AC358. This value is generally conservative. Site-specific K<sub>t</sub> factors can be determined for a given project with full-scale load testing.
- (7) Soil capacities listed are at maximum installation torque. Ultimate soil capacity is based on the equation Q<sub>u</sub> = K<sub>t</sub> × T. Allowable soil capacity is obtained by dividing the ultimate capacity by an appropriate factor of safety (Q<sub>a</sub> = Q<sub>u</sub> / FOS). Although a factor of safety of 2.0 is commonly used, a higher or lower factor of safety may be considered at the discretion of the helical pile designer or as dictated by local code requirements. System capacity should also not exceed the mechanical capacity of the shaft or those listed in the respective bracket capacity tables.

# HP288NCB Bracket Specifications & Capacities when used with the HP287 Helical Pile System

## Bracket Sleeve Material:

Ø3.500" x 0.250" wall  
 ASTM A513 Type 5 Grade 1026  
 Yield strength = 70 ksi (min)  
 Tensile strength = 80 ksi (min)

## Cap Plate Material:

¾" x 6.00" square  
 ASTM A36

## Bracket Hardware:

(2) - Ø¾" Grade 5 bolts with nuts  
 Electrozinc plated per ASTM B633

## Bracket Finish:

Available plain or hot-dip galvanized<sup>(2)</sup>

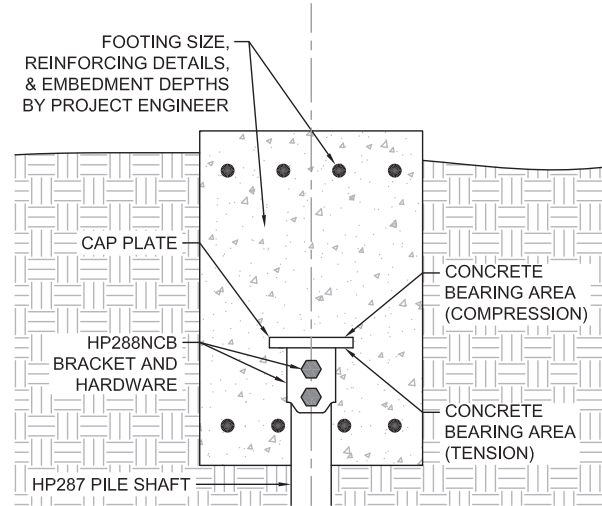

Concrete Bearing Area<sup>(6)</sup> (Compression) = 36.0 in<sup>2</sup>

Concrete Bearing Area<sup>(6)</sup> (Tension) = 26.4 in<sup>2</sup>

		Allowable Bracket Capacity <sup>(4)</sup> R <sub>n</sub> /Ω			
		Compression <sup>(3)</sup> (kips)	Concrete Bearing <sup>(6)</sup> (ksi)	Tension (kips)	Concrete Bearing <sup>(6)</sup> (ksi)
2 Bolts	Plain	55.8	1.55	30.6	1.16
	Plain Corroded <sup>(1)</sup>	45.2	1.27	23.6	0.91
	Galvanized Corroded <sup>(1,2)</sup>	52.9	1.47	27.6	1.05
1 Bolt	Plain	55.8	1.55	15.3	0.58
	Plain Corroded <sup>(1)</sup>	45.2	1.27	11.8	0.45
	Galvanized Corroded <sup>(1,2)</sup>	52.9	1.47	13.8	0.53
0 Bolts <sup>(5)</sup>	Plain	55.8	1.55	0	0
	Plain Corroded <sup>(1)</sup>	45.2	1.27	0	0
	Galvanized Corroded <sup>(1,2)</sup>	52.9	1.47	0	0

- (1) Corroded capacities include a 50-year scheduled sacrificial loss in thickness per ICC-ES AC358.
- (2) Hot-dip galvanized coating in accordance with ASTM A123.
- (3) Allowable capacities consider continuous lateral soil confinement of fully embedded piles. Piles with exposed unbraced lengths or piles placed in fluid soils should be evaluated on a case-by-case basis by the project engineer.
- (4) Listed capacities include limiting mechanical capacities of the shaft when the shaft and bracket are combined as a system. System capacity should also not exceed the installed allowable torque-correlated soil capacity (See Shaft Specifications & Capacities).
- (5) Applications utilizing no bolts should either be tack welded or utilize some other mechanism to immobilize the bracket and maintain firm contact between the cap plate and pile shaft throughout construction and concrete placement.
- (6) Concrete bearing values provided are the uniform bearing stresses required to achieve the full corresponding bracket capacity. Allowable concrete bearing is a function of several project specific variables including depth of embedment, edge distance, and concrete compressive strength (f<sub>c</sub>). When allowable concrete bearing stresses are lower than these values, corresponding bracket capacities can be obtained by multiplying the actual allowable concrete bearing stress by the respective bearing areas provided, but should not exceed the capacities listed in this table. Other concrete design checks including shear, bending, and punching of the supported structure are also project specific and shall be the responsibility of the project engineer.

# HP288NCB8 Bracket Specifications & Capacities when used with the HP287 Helical Pile System

## Bracket Sleeve Material:

Ø3.500" x 0.250" wall  
 ASTM A513 Type 5 Grade 1026  
 Yield strength = 70 ksi (min)  
 Tensile strength = 80 ksi (min)

## Cap Plate Material:

¾" x 8.00" square  
 ASTM A36

## Bracket Hardware:

(2) - Ø¾" Grade 5 bolts with nuts  
 Electrozinc plated per ASTM B633

## Bracket Finish:

Available plain or hot-dip galvanized<sup>(2)</sup>

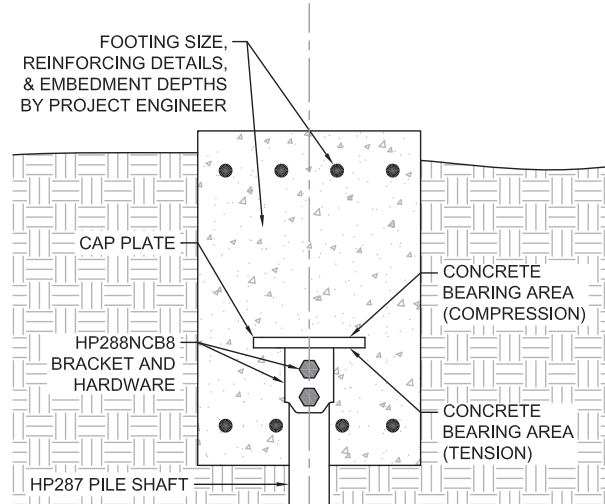

Concrete Bearing Area<sup>(6)</sup> (Compression) = 64.0 in<sup>2</sup>

Concrete Bearing Area<sup>(6)</sup> (Tension) = 54.4 in<sup>2</sup>

		Allowable Bracket Capacity <sup>(4)</sup> R <sub>n</sub> /Ω			
		Compression <sup>(3)</sup> (kips)	Concrete Bearing <sup>(6)</sup> (ksi)	Tension (kips)	Concrete Bearing <sup>(6)</sup> (ksi)
2 Bolts	Plain	47.9	0.75	30.6	0.56
	Plain Corroded <sup>(1)</sup>	43.1	0.68	23.6	0.44
	Galvanized Corroded <sup>(1,2)</sup>	46.6	0.73	27.6	0.51
1 Bolt	Plain	47.9	0.75	15.3	0.28
	Plain Corroded <sup>(1)</sup>	43.1	0.68	11.8	0.22
	Galvanized Corroded <sup>(1,2)</sup>	46.6	0.73	13.8	0.25
0 Bolts <sup>(5)</sup>	Plain	47.9	0.75	0	0
	Plain Corroded <sup>(1)</sup>	43.1	0.68	0	0
	Galvanized Corroded <sup>(1,2)</sup>	46.6	0.73	0	0

- (1) Corroded capacities include a 50-year scheduled sacrificial loss in thickness per ICC-ES AC358.
- (2) Hot-dip galvanized coating in accordance with ASTM A123.
- (3) Allowable capacities consider continuous lateral soil confinement of fully embedded piles. Piles with exposed unbraced lengths or piles placed in fluid soils should be evaluated on a case-by-case basis by the project engineer.
- (4) Listed capacities include limiting mechanical capacities of the shaft when the shaft and bracket are combined as a system. System capacity should also not exceed the installed allowable torque-correlated soil capacity (See Shaft Specifications & Capacities).
- (5) Applications utilizing no bolts should either be tack welded or utilize some other mechanism to immobilize the bracket and maintain firm contact between the cap plate and pile shaft throughout construction and concrete placement.
- (6) Concrete bearing values provided are the uniform bearing stresses required to achieve the full corresponding bracket capacity. Allowable concrete bearing is a function of several project specific variables including depth of embedment, edge distance, and concrete compressive strength (f<sub>c</sub>). When allowable concrete bearing stresses are lower than these values, corresponding bracket capacities can be obtained by multiplying the actual allowable concrete bearing stress by the respective bearing areas provided, but should not exceed the capacities listed in this table. Other concrete design checks including shear, bending, and punching of the supported structure are also project specific and shall be the responsibility of the project engineer.

# FS288BL2 Bracket Specifications & Capacities when used with the HP287 Helical Pile System

## Bracket:

Weldment manufactured from 1/4", 5/16", and 3/8"  
ASTM A572 Grade 50 plate

## External Sleeve:

Ø3.500" x 0.216" wall x 30" long with  
trumpet flare at one end  
ASTM A500 Grade B or C  
Yield strength = 50 ksi (min)  
Tensile strength = 62 ksi (min)

## Cap Plate:

1" x 4.00" x 8.25" ASTM A572 Grade 65

## Bracket Hardware<sup>(3)</sup>:

(2) - Ø3/4" x 16" long all-thread rod Grade B7  
Tensile strength = 125 ksi (min)  
Electrozinc plated per ASTM B633

## Bracket Finish:

Available plain or hot-dip galvanized<sup>(2)</sup>

	Allowable Bracket Capacity <sup>(4,5,6,7)</sup>	
	$R_n/\Omega$	
	(kips)	
Plain	24.2	
Plain Corroded <sup>(1)</sup>	19.9	
Galvanized Corroded <sup>(1,2)</sup>	23.0	

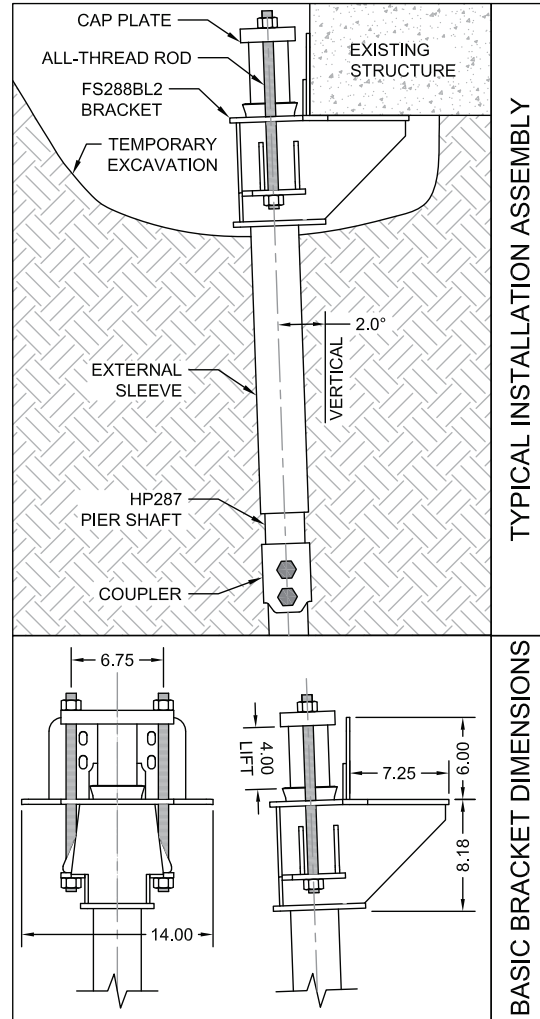

- (1) Corroded capacities include a 50-year scheduled sacrificial loss in thickness per ICC-ES AC358.
- (2) Hot-dip galvanized coating in accordance with ASTM A123.
- (3) Optional hardware utilizes similar sized contour (coil) thread made from AISI 1045, tensile strength = 120 ksi. Slightly lower tensile strength material does not govern the listed capacities.
- (4) Brackets shall be used for support of structures that are considered to be fixed from translation. Structures that are not fixed from translation shall be braced in some manner prior to installing retrofit bracket systems.
- (5) Allowable capacities consider continuous lateral soil confinement of fully embedded piles. Piles with exposed unbraced lengths or piles placed in fluid soils should be evaluated on a case-by-case basis by the project engineer.
- (6) Concrete bearing assumes a minimum compressive strength ( $f'_c$ ) of 2,500 psi. Local concrete bending and other local design checks should be evaluated on a case-by-case basis by the project engineer.
- (7) Listed allowable capacities are for the specific shaft/bracket combination shown. System capacity should also not exceed the installed torque-correlated soil capacity (See Shaft Specifications & Capacities).

# FS288BL2V Bracket Specifications & Capacities when used with the HP287 Helical Pile System

## Bracket:

Weldment manufactured from 1/4", 5/16", and 3/8"  
ASTM A572 Grade 50 plate

## External Sleeve:

Ø3.500" x 0.216" wall x 30" long with  
trumpet flare at one end  
ASTM A500 Grade B or C  
Yield strength = 50 ksi (min)  
Tensile strength = 62 ksi (min)

## Cap Plate:

1" x 4.00" x 8.25" ASTM A572 Grade 65

## Bracket Hardware<sup>(3)</sup>:

(2) - Ø3/4" x 16" long all-thread rod Grade B7  
Tensile strength = 125 ksi (min)  
Electrozinc plated per ASTM B633

## Bracket Finish:

Available plain or hot-dip galvanized<sup>(2)</sup>

	Allowable Bracket Capacity <sup>(4,5,6,7)</sup>	
	$R_n/\Omega$	
	(kips)	
Plain	24.2	
Plain Corroded <sup>(1)</sup>	19.9	
Galvanized Corroded <sup>(1,2)</sup>	23.0	

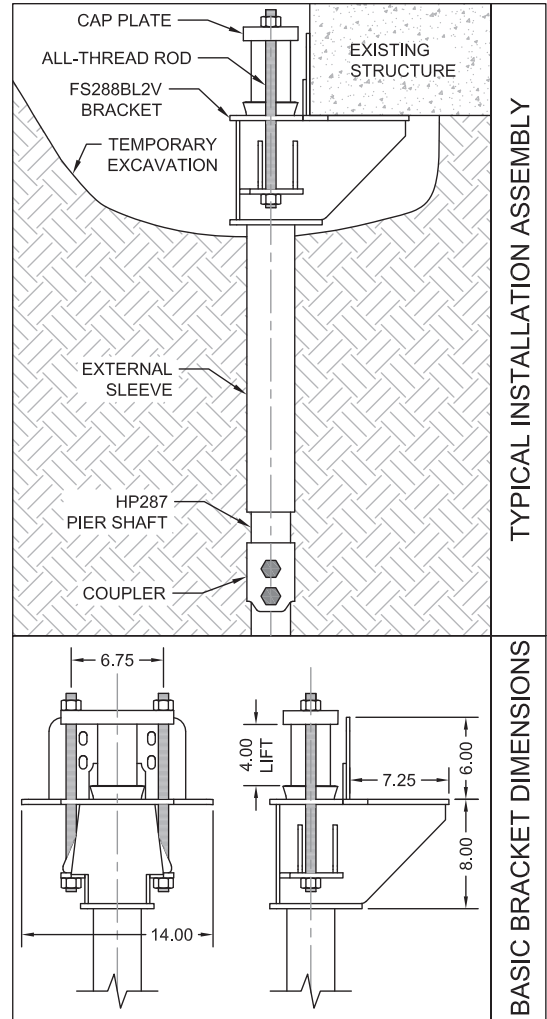

- (1) Corroded capacities include a 50-year scheduled sacrificial loss in thickness per ICC-ES AC358.
- (2) Hot-dip galvanized coating in accordance with ASTM A123.
- (3) Optional hardware utilizes similar sized contour (coil) thread made from AISI 1045, tensile strength = 120 ksi. Slightly lower tensile strength material does not govern the listed capacities.
- (4) Brackets shall be used for support of structures that are considered to be fixed from translation. Structures that are not fixed from translation shall be braced in some manner prior to installing retrofit bracket systems.
- (5) Allowable capacities consider continuous lateral soil confinement of fully embedded piles. Piles with exposed unbraced lengths or piles placed in fluid soils should be evaluated on a case-by-case basis by the project engineer.
- (6) Concrete bearing assumes a minimum compressive strength ( $f'_c$ ) of 2,500 psi. Local concrete bending and other local design checks should be evaluated on a case-by-case basis by the project engineer.
- (7) Listed allowable capacities are for the specific shaft/bracket combination shown. System capacity should also not exceed the installed torque-correlated soil capacity (See Shaft Specifications & Capacities).

# HP288B2 Bracket Specifications & Capacities when used with the HP287 Helical Pile System

## Bracket:

Weldment manufactured from  $\frac{3}{8}$ "  
ASTM A36 plate

## Integrated External Sleeve:

$\varnothing 3.500$ " x 0.216" wall x 20" long  
ASTM A500 Grade B or C  
Yield strength = 50 ksi (min)  
Tensile strength = 62 ksi (min)

## Cap Plate:

1" x 4.00" x 8.25" ASTM A572 Grade 65

## Bracket Hardware<sup>(3)</sup>:

(2) -  $\varnothing \frac{3}{4}$ " x 16" long all-thread rod Grade B7  
Tensile strength = 125 ksi (min)  
Electro-zinc plated per ASTM B633

## Bracket Finish:

Available plain or hot-dip galvanized<sup>(2)</sup>

	Allowable Bracket Capacity <sup>(4,5,6,7)</sup>	
	$R_n/\Omega$	
	(kips)	
Plain	21.0	
Plain Corroded <sup>(1)</sup>	17.2	
Galvanized Corroded <sup>(1,2)</sup>	19.9	

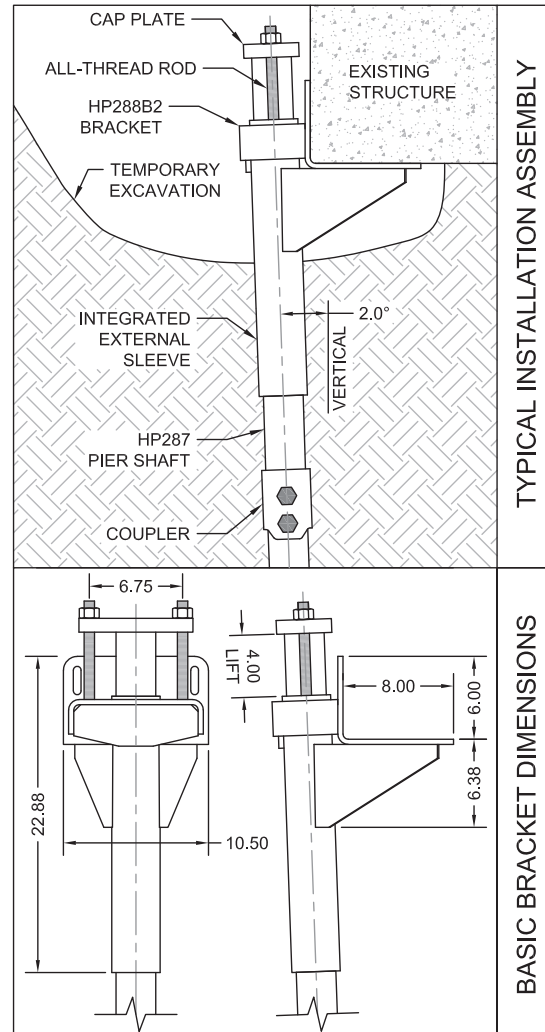

- (1) Corroded capacities include a 50-year scheduled sacrificial loss in thickness per ICC-ES AC358.
- (2) Hot-dip galvanized coating in accordance with ASTM A123.
- (3) Optional hardware utilizes similar sized contour (coil) thread made from AISI 1045, tensile strength = 120 ksi. Slightly lower tensile strength material does not govern the listed capacities.
- (4) Brackets shall be used for support of structures that are considered to be fixed from translation. Structures that are not fixed from translation shall be braced in some manner prior to installing retrofit bracket systems.
- (5) Allowable capacities consider continuous lateral soil confinement of fully embedded piles. Piles with exposed unbraced lengths or piles placed in fluid soils should be evaluated on a case-by-case basis by the project engineer.
- (6) Concrete bearing assumes a minimum compressive strength ( $f'_c$ ) of 2,500 psi. Local concrete bending and other local design checks should be evaluated on a case-by-case basis by the project engineer.
- (7) Listed allowable capacities are for the specific shaft/bracket combination shown. System capacity should also not exceed the installed torque-correlated soil capacity (See Shaft Specifications & Capacities).

# HP288BUL2 Bracket Specifications & Capacities when used with the HP287 Helical Pile System

## Bracket:

Weldment manufactured from  $\frac{5}{16}$ " and  $\frac{1}{2}$ "  
ASTM A572 Grade 50 plates

## Integrated External Sleeve:

$\varnothing 3.500$ " x 0.216" wall x 20" long  
ASTM A500 Grade B or C  
Yield strength = 50 ksi (min)  
Tensile strength = 62 ksi (min)

## Cap Plate:

1" x 4.00" x 8.25" ASTM A572 Grade 65

## Bracket Hardware<sup>(3)</sup>:

(2) -  $\varnothing \frac{3}{4}$ " x 16" long all-thread rod Grade B7  
Tensile strength = 125 ksi (min)  
Electrozinc plated per ASTM B633

## Bracket Finish:

Available plain or hot-dip galvanized<sup>(2)</sup>

	Allowable Bracket Capacity <sup>(4,5,6,7)</sup>	
	$R_n/\Omega$	
	(kips)	
Plain	18.0	
Plain Corroded <sup>(1)</sup>	14.7	
Galvanized Corroded <sup>(1,2)</sup>	17.1	

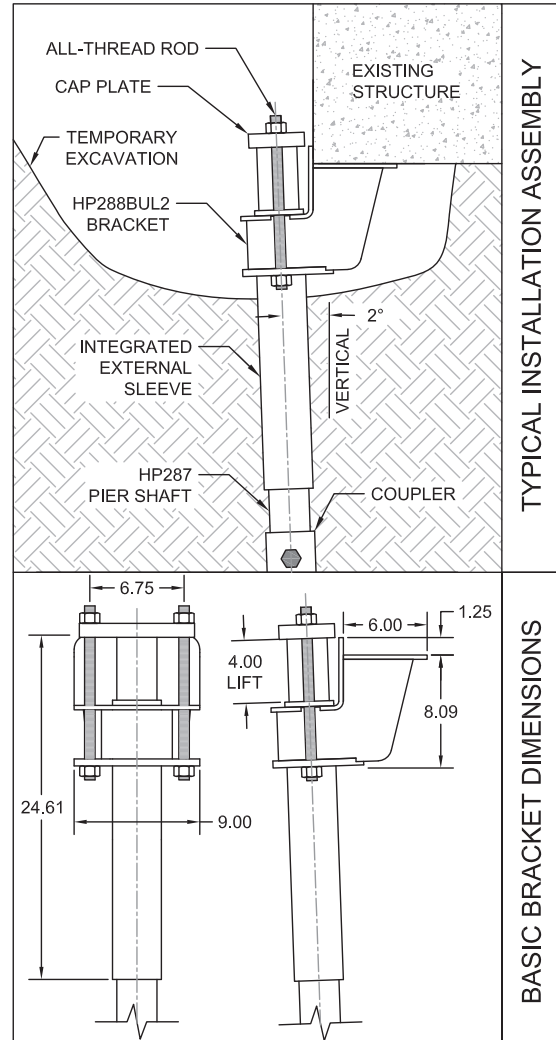

- (1) Corroded capacities include a 50-year scheduled sacrificial loss in thickness per ICC-ES AC358.
- (2) Hot-dip galvanized coating in accordance with ASTM A123.
- (3) Optional hardware utilizes similar sized contour (coil) thread made from AISI 1045, tensile strength = 120 ksi. Slightly lower tensile strength material does not govern the listed capacities.
- (4) Brackets shall be used for support of structures that are considered to be fixed from translation. Structures that are not fixed from translation shall be braced in some manner prior to installing retrofit bracket systems.
- (5) Allowable capacities consider continuous lateral soil confinement of fully embedded piles. Piles with exposed unbraced lengths or piles placed in fluid soils should be evaluated on a case-by-case basis by the project engineer.
- (6) Concrete bearing assumes a minimum compressive strength ( $f'_c$ ) of 2,500 psi. Local concrete bending and other local design checks should be evaluated on a case-by-case basis by the project engineer.
- (7) Listed allowable capacities are for the specific shaft/bracket combination shown. System capacity should also not exceed the installed torque-correlated soil capacity (See Shaft Specifications & Capacities).

# HP288BML Bracket Specifications & Capacities when used with the HP287 Helical Pile System

## Bracket:

Weldment manufactured from  $\frac{3}{8}$ "  
ASTM A36 plate

## Integrated External Sleeve:

$\varnothing 3.500$ " x 0.216" wall x 20" long  
ASTM A500 Grade B or C  
Yield strength = 50 ksi (min)  
Tensile strength = 62 ksi (min)

## Bracket Hardware:

(1) -  $\varnothing 1\frac{1}{4}$ " x 6" long lifting bolt with nut Grade 5  
Tensile strength = 105 ksi (min)  
Electrozinc plated per ASTM B633

## Bracket Finish:

Available plain or hot-dip galvanized<sup>(2)</sup>

	Allowable Bracket Capacity <sup>(3,4,5,6)</sup>	
	$R_n/\Omega$	
	(kips)	
Plain	12.0	
Plain Corroded <sup>(1)</sup>	9.8	
Galvanized Corroded <sup>(1,2)</sup>	11.4	

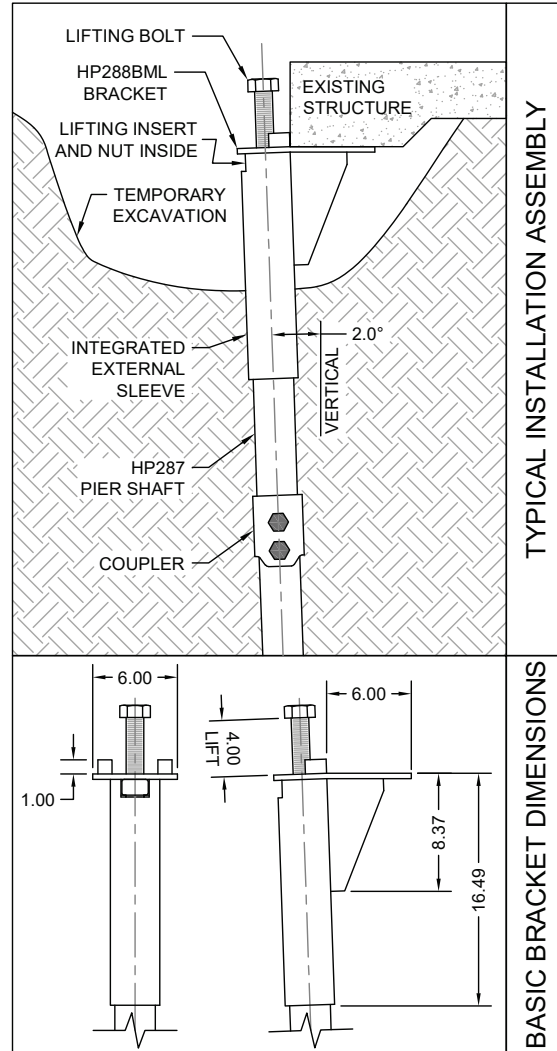

- (1) Corroded capacities include a 50-year scheduled sacrificial loss in thickness per ICC-ES AC358.
- (2) Hot-dip galvanized coating in accordance with ASTM A123.
- (3) Brackets shall be used for support of structures that are considered to be fixed from translation. Structures that are not fixed from translation shall be braced in some manner prior to installing retrofit bracket systems.
- (4) Allowable capacities consider continuous lateral soil confinement of fully embedded piles. Piles with exposed unbraced lengths or piles placed in fluid soils should be evaluated on a case-by-case basis by the project engineer.
- (5) Concrete bearing assumes a minimum compressive strength ( $f'_c$ ) of 2,500 psi. Local concrete bending and other local design checks should be evaluated on a case-by-case basis by the project engineer.
- (6) Listed allowable capacities are for the specific shaft/bracket combination shown. System capacity should also not exceed the installed torque-correlated soil capacity (See Shaft Specifications & Capacities).

## HP287 Helix Plate Net Bearing Areas

### H-Style Plates

Plate Diameter (inches)	Area (ft <sup>2</sup> )
6	0.15
8	0.30
10	0.50
12	0.74
14	1.02
16	1.35

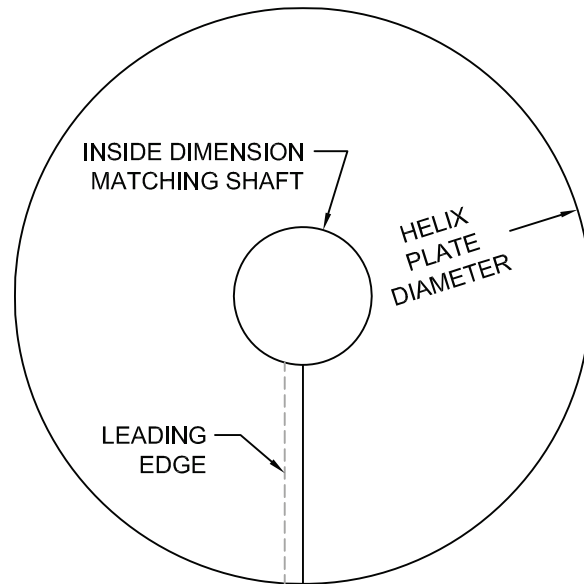

### V-Style Plates<sup>(1)</sup>

Plate Diameter (inches)	Area (ft <sup>2</sup> )
6	0.14
8	0.28
10	0.45
12	0.66
14	0.91
16	1.19

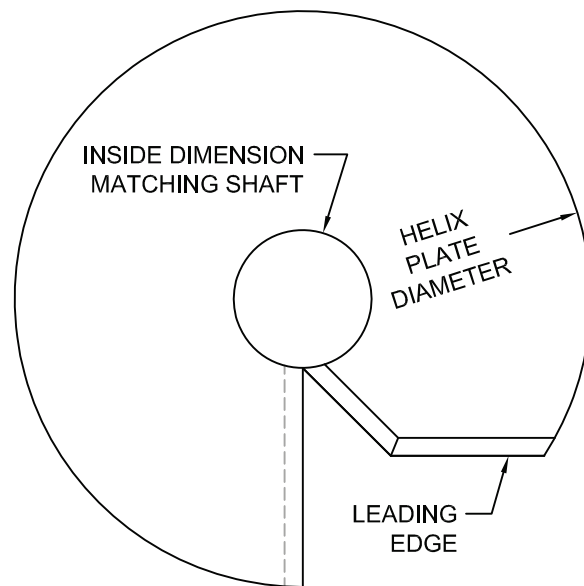

- (1) V-Style plates feature a special cut on the leading edge (or cutting edge). This edge is cut at two successive 45° angles to roughly simulate a spiral. This is in addition to the 45° bevel on the leading edge which is a standard feature for helix plates of both styles. V-Style plates are appropriate for use in applications where rocky or rubble-filled soils are anticipated, or where very dense layers need to be penetrated.